

Commercial Waffle Maker User Manual

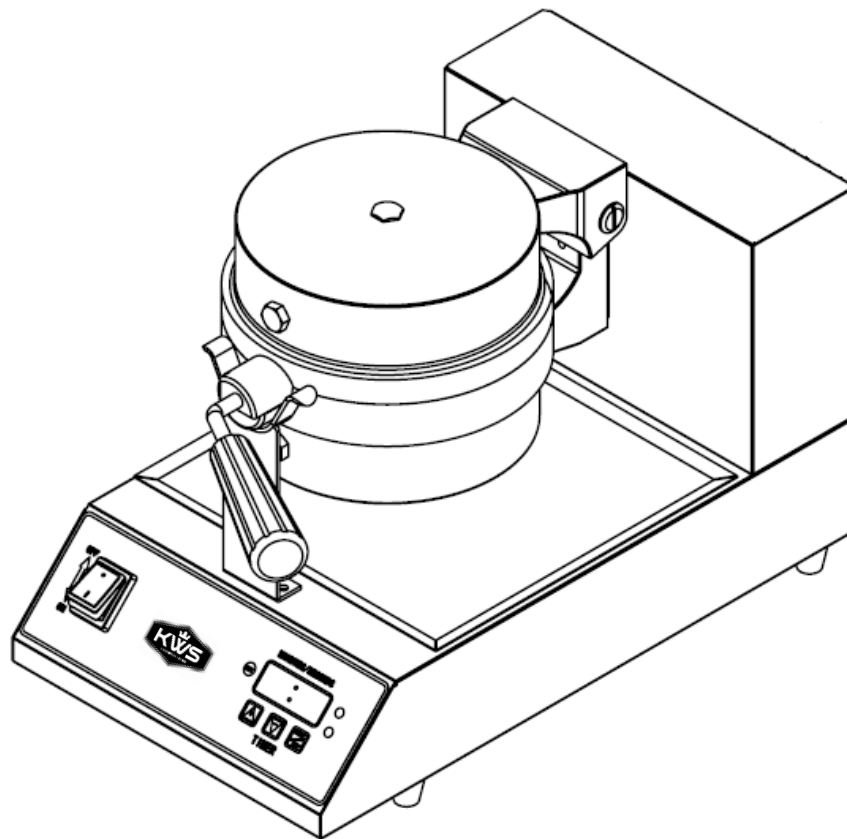

Thank you for purchasing this KitchenWare Station waffle maker. Before operating the equipment, read and familiarize yourself with the following operating and safety instructions.

SAVE THESE INSTRUCTIONS FOR FUTURE REFERENCE.



Table of Contents

Unpacking.....	3
Safety Instruction.....	4
Features and Controls.....	5
Operating Instructions	6
Belgian Waffles Recipe	7
Cleaning and Sanitizing Instruction	9
Technical Parameters.....	10
Circuit Diagram	10
Waffle maker Component List	11
Troubleshooting.....	12
Customer Care	13
Limited Warranty.....	14

UPON RECEIVING

UNPACKING:

The commercial waffle maker was inspected before leaving the factory. The carrier assumes full responsibility for safe delivery upon acceptance of the shipment.

1. Unpack the commercial waffle maker immediately after receipt. If the machine is found to be damaged after unpacking, save the packaging material and contact carrier and KitchenWare Station Customer Service Department within seven (7) days of delivery.
2. You should receive the waffle maker, a removable drip tray and an instruction manual. Contact KitchenWare Station Customer Service Department if you did not receive all of these materials or if you need additional spare parts.



The electrical cord on this machine is equipped with a three- prong grounding plug which must be connected to a properly grounded receptacle. If the receptacle is not the proper grounding type, contact a certified electrician. Do not remove the grounding prong from the plug.

3. Examine commercial waffle maker to make sure all parts have been provided.
4. Make sure that the instruction manual is available near commercial waffle maker.
5. Complete the online warranty/registration at: www.kitchenwarestation.com/registration/
6. Before use, clean and sanitize commercial waffle maker. Refer to Cleaning and Sanitizing.
7. Contact your local representative or KitchenWare Station directly if you have any questions or problems with the installation or operation of this commercial waffle maker.



IMPORTANT SAFETY INSTRUCTION

Thank you for purchasing KitchenWare Station commercial waffle maker. Each unit has been manufactured to ensure safety and reliability. Before using for the first time, please read the instructions carefully and keep them for further reference.

WARNING! READ AND SAVE THESE INSTRUCTIONS. Failure to follow all of the instructions listed below may result in electric shock, fire and/ or serious personal injury.

- ❖ **NEVER** touch commercial waffle maker without training and authorization from your supervisor or if you are under 18 years old.
- ❖ Read this manual thoroughly before installation and operation. **DO NOT** continue with installation and operation if you have any questions or do not understand anything in the manual. Contact KitchenWare Station Customer Service Department for further assistance.
- ❖ To avoid electrical hazards, do **NOT** place the commercial waffle maker in or near water or other liquid.
- ❖ Plug only into grounded electrical outlets matching the nameplate rated voltage.
- ❖ Do **NOT** operate unattended.
- ❖ **ONLY** install commercial waffle maker on a level, nonskid surface in a clean, well-lighted work area away from children and visitors.
- ❖ Do **NOT** use an extension cord with this equipment. Do not plug this equipment into a power strip or multi-outlet power cord.
- ❖ Check equipment before each use to ensure the equipment is clean.
- ❖ Wear proper apparel. Do not wear loose fitting or hanging garments while operating this equipment.
- ❖ Unplug equipment, turn off and let it cool completely before cleaning or moving.
- ❖ Do **NOT** clean the equipment with steel wool or high-pressure spray gun.
- ❖ Keep equipment and power cord away from open flames, electric burners, or excessive heat.
- ❖ Do **NOT** operate if equipment has been damaged or is malfunctioning in any way.
- ❖ Before cleaning, servicing, or removing any parts, always turn commercial waffle maker off and unplug unit.
- ❖ Keep unit **UNPLUGGED** when not in use to prevent accidental start up.
- ❖ **DO NOT** use outdoors. For indoor use only

FEATURES AND CONTROLS

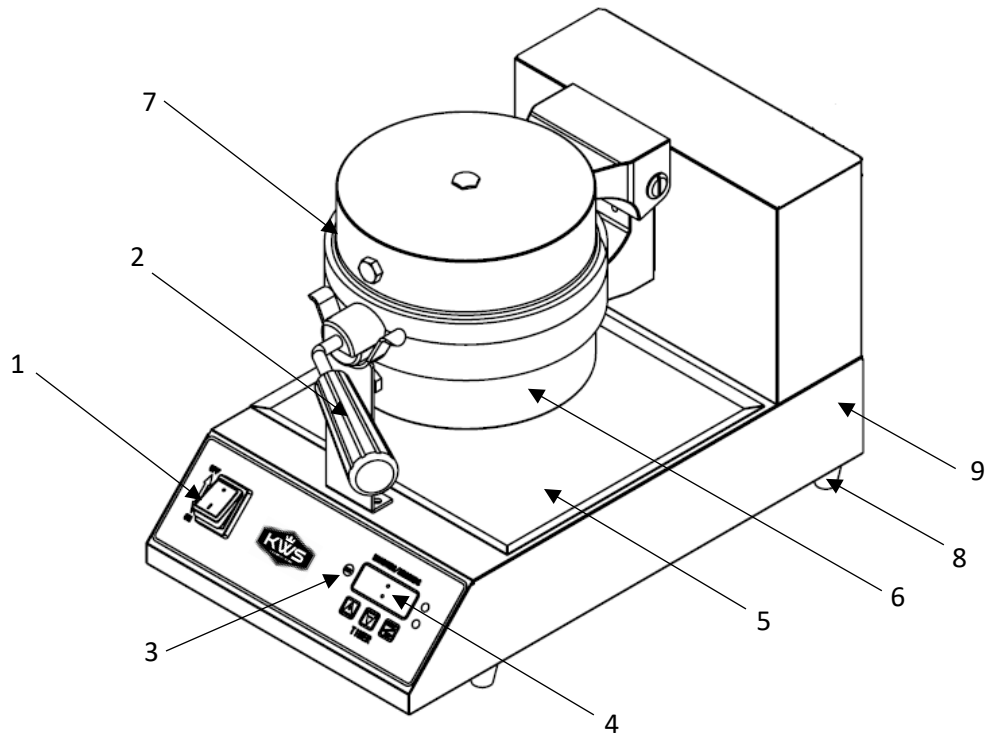

- | | | |
|-------------------|----------------|--------------------------|
| 1. On/Off Buttons | 2. Grip Handle | 3. Temperature Regulator |
| 4. Timer | 5. Drip Tray | 6. Bottom Grid Plate |
| 7. Top Grid Plate | 8. Leg | 9. Base |



OPERATING INSTRUCTIONS

LOCATION

Place the commercial waffle maker on a suitable counter or tabletop. Allow enough space around the waffle maker for safety operation.

- Keep the commercial waffle maker away from heat sources and not in a passageway.
- Before use, clean and sanitize waffle maker. Refer to Cleaning and Sanitizing.
- Make sure that the place is dry, not humid, dust-free, clean, and free from insects or other animals.

FEATURES

TEMPERATURE REGULATOR

Determines the temperature of the waffle maker.

TIMER

Determines the amount of time use making waffle. The function of timer will not auto cut off the power.

OVERHEAT PROTECTION

The automatic shut off feature will cut power when the machine has reached maximum allowable temperature.

CONTROLS

On Off Switch Press "I" pushbutton to turn on the waffle maker

Press "o" pushbutton to turn off the waffle maker

BEFORE USING YOUR WAFFLE MAKER

Before using the appliance for the first time, please follow these simple instructions:

1. Be certain that all protective plastics and residues are removed from all surfaces.
2. Clean the appliance thoroughly before using the unit.
3. Place on a firm and stable surface.



4. Make sure that all parts are dry.
5. Warm up unit for approximate 20 minutes. This will allow all oils and other sediment to burn off.

Program Timer

1. Press and hold the ▲ or ▼ button.
2. Press the “Start/ Stop” button to gradually increase or decrease the time.

Temperature Setting

1. Press and hold the “Set” and “Start/ Stop” buttons at the same time.
2. Then press the ▲ or ▼ button to adjust desired temperature.

COMMERCIAL WAFFLE MAKER OPERATION

1. Turn the power switch to on “I”.
2. Set to desired temperature. Refer to Temperature Setting.
3. Allow grid plate to warm up.
4. When set temperature is reached, signal light will turn from green to yellow.
5. Lift the handle to open waffle maker.
6. Pour the batter evenly into the center of the bottom grid plate.
7. Close the grid plate by pressing the handle down.
8. Rotate the unit 180 degrees.
9. Press the “Start/ Stop” button to start the timer.
10. Once the timer buzzes, turn the waffle maker back over.
11. Open waffle maker and remove the waffle using a pair of tongs.
12. Repeat step 5 - 10 to make new waffle.
13. Turn machine off and unplug from power source when no longer needed.



Belgian Waffles Recipe

Ingredients:

- 3 cups of Cake Flour
 - 1/4 cup of Custard Powder
 - 1 package/ .25oz Active Dry Yeast
 - 3 Tbsp of Granulated Sugar
 - 1/2 tsp of Salt
 - 1/2 tsp of Baking Soda
 - 1-1/2 tsp of Baking Powder
 - 1/2 cup of Melted Butter
 - 2 Eggs
 - 1 tsp of Vanilla Extract
 - 2-1/3 cups of Warm Milk
 - 1/4 cup of Warm Water
- (About 115 degrees Fahrenheit)

Preparation:

1. To the warm water, sprinkle in about 1/2 tsp of sugar and the yeast, allow the yeast to proof for about 3 – 4 minutes.
2. In a bowl, mix together all the dry ingredients: cake flour, custard powder, salt, baking soda, baking powder. Sift your flour and custard powder for a smoother batter.
3. In a separate big bowl, whisk together the eggs, milk, water mixture, vanilla, butter, and remaining sugar.
4. Add the dry ingredients into the wet and mix it just long enough to incorporate all ingredients.
5. Cover your bowl and allow it to rest for about an hour, your batter should be double in size when it is ready.

Note: You can also make this batter at night, cover with plastic wrap/ lid and put it in the fridge overnight. The batter will slowly rise and ready to use in the morning.

6. Preheat your KWS waffle maker and follow the operation instruction in P. 7.
7. Serve them with nut butter and condense milk or some fresh berries!

CLEANING AND SANITIZING

IMPORTANT: To maintain the appearance and increase the service life, clean and sanitize your equipment daily after use. Clean before use if equipment has not been used for a while.



- BEFORE CLEANING, SERVICING, OR DISASSEMBLE ANY PARTS, always turn commercial waffle maker OFF and unplug unit.
- NEVER attempt to clean commercial waffle maker while waffle maker is in operation.
- DO NOT put components in the dishwasher or immerse base in water.
- DO NOT hose down, pressure wash, or pour water on commercial waffle maker.
- NEVER use a scrubber pad, steel wool, or abrasive material to clean waffle maker.

1. Turn off the machine and unplug the unit.
2. Leave top lid open and allow the waffle maker to cool completely before moving the machine or cleaning.
3. Remove drip tray.
4. Wash, rinse, and sanitize removed drip tray, and let it air dry.
5. Absorb any excess cooking oil on grid plates by wiping with a dry cloth or paper towel.
6. To help remove oil buildup and batter residue, place a damp paper towel in between the grid plates and close the lid. Allow to sit for a few minutes.
7. If batter adheres to plates, simply pour a little cooking oil onto the baked batter, and let it stand approximately for 5 minutes. This will allow the batter to soften for easy removal.
8. Wipe down unit using a damp cloth or sponge and hot neutral detergent water (50/50 hot water and dish soap).
Note: Do NOT use cold water on warm plates.
9. Rinse by wiping with a damp cloth.
10. To clean exterior, wipe with a soft, dry cloth.
11. Make sure that all parts and surfaces are fully air dry before storage.

TECHNICAL PARAMETERS

Model Number	WM-100	WM-300
Voltage	120V/ 60Hz~	120V / 60Hz~
Power	1547W	1547W + 1547W
Temperature Control Range (F)	255 °F - 446 °F	255 °F - 446 °F
Timer Range	0 sec – 99 min 59 sec	0 sec – 99 min 59 sec
Product Dimension	10" x 20.8" x 11.3"	20.5" x 20.8" x 11.3"

Circuit Diagram

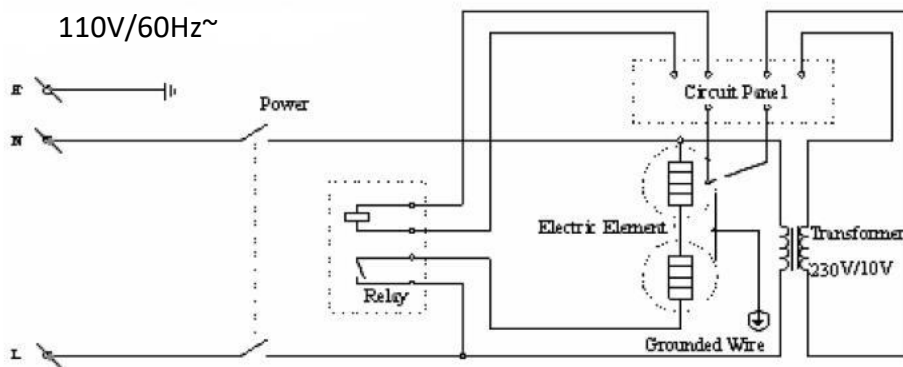

Models:

WM-100, WM-300

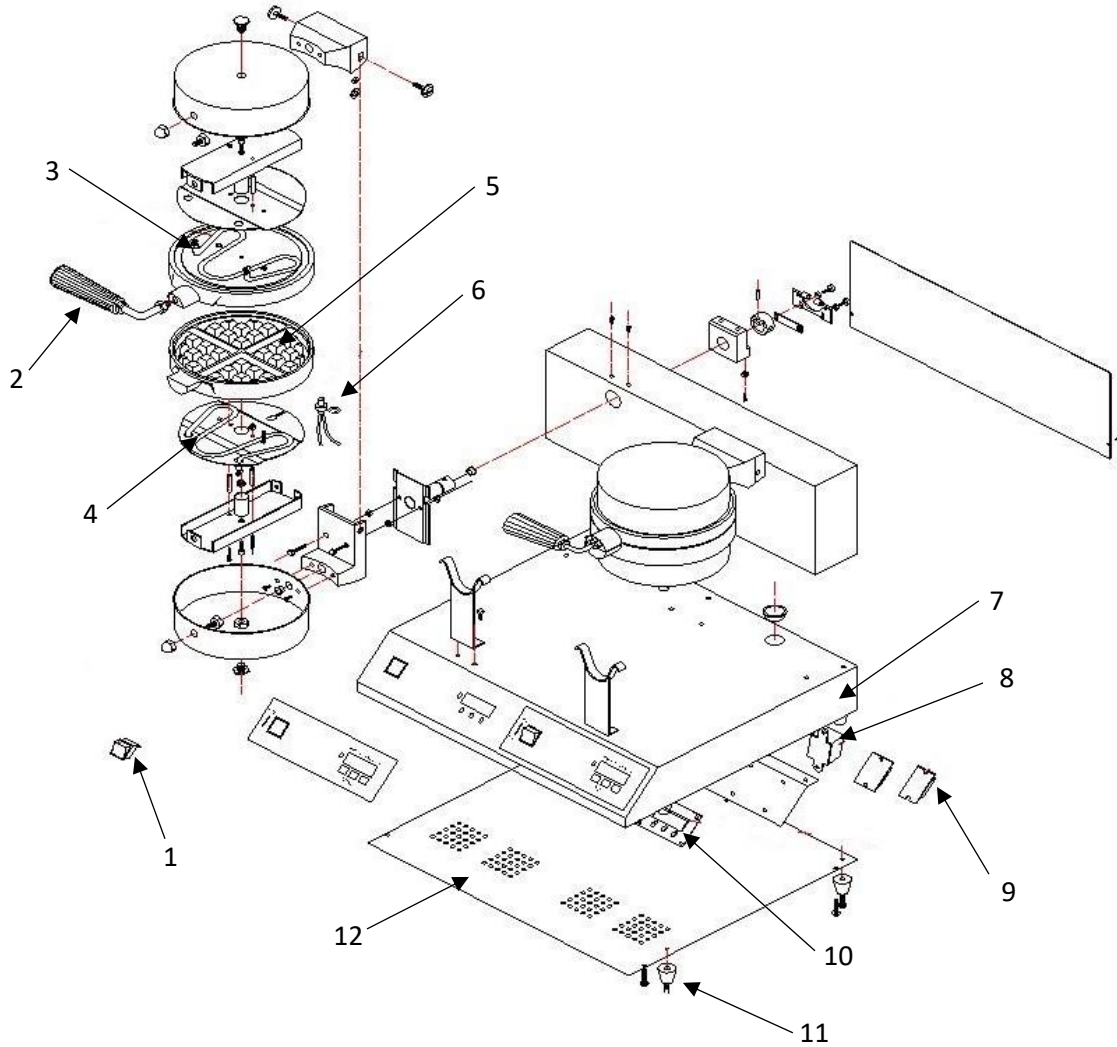

Part No.	Description	Part No.	Description
1	ON- OFF SWITCH	7	BASE
2	GRIP HANDLE	8	TRANSFORMER
3	TOP HEATING ELEMENT	9	CONTACTOR
4	BOTTOM HEATING ELEMENT	10	CONTROL BOARD
5	TOP GRID PLATE	11	LEG
6	THERMOCOUPLE	12	BASE COVER



TROUBLESHOOTING GUIDE

Issue	Cause	Solution
Commercial waffle maker not working	Waffle maker not plugged in	Plug in waffle maker
	Lack of power from the electrical network	Restore the supply of power from the electrical network
	Machine's On-Off switch is in "o" position	Push the green button to "I" position
	Damaged On-Off switch	Contact dealer or KitchenWare Station customer service team to have the damaged part replaced
	Thermal cut out has activated	Turn Off waffle maker, let waffle maker cool and then clean on or around elements removing the food debris
Grid plates are not heating up and indicator light is ON	Damage thermostat	Contact dealer or KitchenWare Station customer service team for assistance
	Thermal cut out has activated	Turn Off waffle maker, let waffle maker cool and then clean on or around elements removing the food debris
	Damage heating tubes	Contact dealer or KitchenWare Station customer service team to have the damaged part replaced
Indicator light is OFF, but waffle maker is heating	Damaged indicator light	Contact dealer or KitchenWare Station customer service team to have the damaged part replaced

If problems persist and the assigned solution does not remedy the issue, please call KitchenWare Station Service Department at: 888-505-3698 or 626-899-4843.



CUSTOMER CARE

If you have any questions with regard to the operation of this commercial waffle maker or are in need of a spare part, please contact KitchenWare Station Customer Service Department.

KitchenWare Station, LLC

13732 Milroy Pl

Santa Fe Springs, CA 90670

Toll Free: 1-888-505-3698 (Monday – Friday 10:30am – 5pm PST)

Email: Customerservice@kitchenwarestation.com

Official Website: <http://www.kitchenwarestation.com>

NOTE: Spare Parts can be purchased directly on KitchenWare Station official website, or contact customer service department if part not found.



LIMITED WARRANTY

Thank you for purchasing KitchenWare Station's product. This WM model's commercial waffle makers were tested and meets our stringent quality standards. This product is warranted to be free from manufacturing defects under normal/ proper use and conditions for 1 year.

To register your warranty for this product, complete the warranty registration form provided in the package, and send it back to us. Or register online by visiting www.kitchenwarestation.com/registration.

If you have any questions or comments, please do not hesitate to Email our customer service team: customerservice@kitchenwarestation.com . Please specify the model number and order ID so our customer service department can assist you.

KitchenWare Station's obligation and liability under this warranty is expressly limited to repair or replacement for equipment that proves to be manufacturing defects under normal/ proper use within the applicable warranty period.

This warranty does not apply to defects due directly or indirectly to fire, water, burglary, misuse, abuse, negligence, accidents, repairs, alterations, lack of maintenance, punitive damages, loss of use, down time, lost profit, improper installation by unauthorized persons, low voltage conditions, inadequate wiring or normal wear and tear. Defects mentioned above are not manufacturing defects and are strictly the responsibility of the purchaser. Under no circumstances will KitchenWare Station be liable for incidental or consequential damages resulting from defective products. Seller shall in no event be liable for death, injuries to persons or property, or for incidental, contingent, special, or consequential damages arising from the use of our products.

Warranty valid only in the 48 contiguous United States plus the District of Columbia. KitchenWare Station reserves the right to change the price and specifications of the equipment and/ or material without notice. Prices are F.O.B plant of manufacture.

Any instructions or warranty included in this manual may be subject to change without notice. For the most up to date instructions and warranty information, please visit our official website.

To receive warranty instructions and return authorization, please email KitchenWare Station Customer Service.

For more information regarding warranty and limitation, please visit www.kitchenwarestation.com/warranty-information/